

Product Information

Sensors and Instrumentation

**Flow Transmitter /
 Switch OMNI-MID1**



- For all electrically conductive fluids
- No moving parts in the area of flow
- High overload protection
- Low pressure loss
- Analog output, two switching outputs
- Clear, easily legible, illuminated graphic LCD display
- Modifiable units in the display
- Small, compact construction

Characteristics

The MID1 system consists of a number of sensors which measure the flow speed of a flowing fluid according to the principle of Faraday's law of induction. For this, the fluid must have a minimum electrical conductivity of 50 µS/cm. Three nominal widths are available.

The sensors are available with different evaluation electronics, which vary in type and number of outputs, and in operating convenience.

The OMNI transducer located on the sensor has a backlit graphics LCD display which is very easy to read, both in the dark and in bright sunlight. The graphics display allows the presentation of measured values and parameters in a clearly understandable form. The measured values are displayed to 4 places, together with their physical unit, which may also be modified by the user. The electronics have an analog output (4..20 mA or 0..10 V) and two switching outputs, which can be used as limit switches for monitoring minima or maxima, or as two-point controllers.

The switching outputs are designed as push-pull drivers, and can therefore be used both as PNP and NPN outputs. Exceeding limit values is signalled by a red LED which is visible over a long distance, and by a cleartext in the display. The stainless steel case has a hardened non-scratch mineral glass pane. It is operated by a programming ring fitted with a magnet, so there is no need to open the operating controls housing, and its leakproofness is permanently ensured.

By turning the ring to right or left, it is simple to modify the parameters (e.g. switching point, hysteresis...). To protect from unintended programming, it can be removed, turned through 180 ° and replaced, or completely removed, thus acting as a key.



Technical data

Sensor	magnetic-inductive	
Nominal width	DN 8..25	
Process connection	male thread R 1/4", R 1/2", R 1"	
Metering ranges	0.05..60 l/min	for details, see table "Ranges"
Measurement accuracy	0.05..1.5 l/min	
Repeatability	1 %	
Minimum electrical conductivity (medium)	50 µS/cm	
Pressure	PN 10	
Pressure loss	max. 0.3 bar at max. flow	
Medium temperature	0..60 °C (avoid frost and dew)	
Ambient temperature	0..60 °C	
Storage temperature	-20..+80 °C	
Materials medium-contact	stainless steel 1.4404, PPS, FKM	
Materials, non-medium-contact	Housing	stainless steel 1.4305
	Glass	mineral glass, hardened
	Magnet	samarium-Cobalt
	Ring	POM
Supply voltage	18..24 V DC	
Power consumption	< 1 W	
Analog output	4..20 mA / max. load 500 Ω or 0..10 V / min. load 1 kΩ	
Switching outputs	transistor output "push-pull" (resistant to short circuits and polarity reversal) I _{out} = 100 mA max.	
Hysteresis	adjustable, position of the hysteresis depends on minimum or maximum	
Display	backlit graphical LCD-Display (transreflective), extended temperature range -20..+70 °C, 32 x 16 pixels, background illumination, displays value and unit, flashing LED signal lamp with simultaneous message on the display.	
Electrical connection	for round plug connector M 12x1, 5-pole	
Ingress protection	IP 64	
Weight	R 1/4"	approx. 0.35 kg
	R 1/2"	approx. 0.35 kg
	R 1"	approx. 0.45 kg

Product Information

Sensors and Instrumentation

Ranges

R	Nominal width	Metering range l/min H2O	Measurement accuracy
R 1/4"	DN 8	0.05.. 1	2.5 % of the measured value, at least 0.005 l/min
R 1/2"	DN 15	0.50..10	2.5 % of the measured value, at least 0.05 l/min
R 1"	DN 25	3.00..60	2.5 % of the measured value, at least 0.3 l/min

Wiring

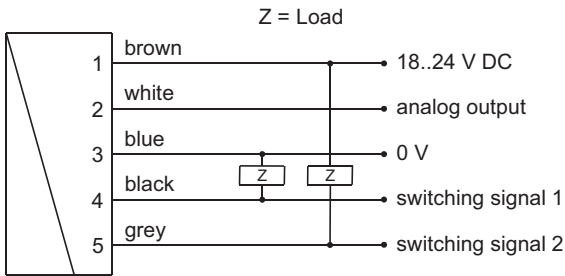

Connection example: PNP NPN

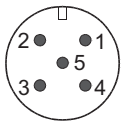

Before the electrical installation, it must be ensured that the supply voltage corresponds to the data sheet. The use of shielded cabling is recommended.

Dimensions

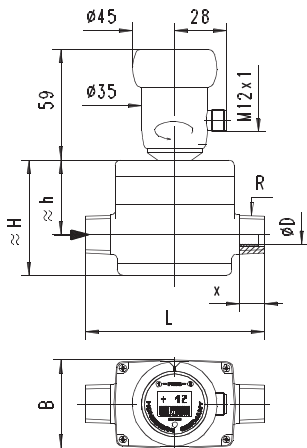

	L mm	H mm	h mm	R	x mm	B mm	D mm
OMNI-MID1-008	85	59	39	1/4"	9	47	5
OMNI-MID1-015	95	63	42	1/2"	13	47	10
OMNI-MID1-025	110	72	45	1"	16	49	20

Handling and operation

Installation

The device is screwed into the pipework by means of two male threads or into suitable connection pieces. Here, attention must be paid to the direction (arrow marked on the housing in the direction of flow). Seal using Teflon tape or a fluid seal.

Use the following torques:

- R 1/4": 3 ±0.5 Nm
- R 1/2" 5 ±0.5 Nm
- R 1 12 ±1.0 Nm

The sensor can be operated in any location. However, air bubbles should be avoided. Direction of flow from bottom to top is recommended.

The electronics head is supplied mounted on the sensor body.

Avoid angular loading of the sensor. Pipework in which sensors are installed should be permanently flooded. 10 x D should be used in the inlet and outlet.

Programming

The annular gap of the programming ring can be turned to positions 1 and 2. The following actions are possible:



Set to 1 = continue (STEP)
Set to 2 = modify (PROG)

Neutral position between 1 and 2

The ring can be removed to act as a key, or turned through 180° and replaced to create a programming protector. Operation is by dialog with the display messages, which makes its use very simple.

Starting from the normal display (present value and unit), if 1 (STEP) is repeatedly selected, then the display shows the following information in this order:

Display of the parameters, using position 1

- Switching value S1 (switching point 1 in the selected unit)
- Switching characteristic of S1
MIN = Monitoring of minimum value
MAX = Monitoring of maximum value
- Hysteresis 1 (hysteresis value of S1 in the set unit)
- Switching value S2
- Switching characteristic of S2
- Hysteresis 2
- Code
- After entering the **code 111**, further parameters can be defined:
 - Filter (settling time of the display and output)
 - Physical unit (Units)
 - Output: 0..20 mA or 4..20 mA
 - 0/4 mA (measured value corresponding to 0/4 mA)
 - 20 mA (measured value corresponding to 20 mA)

For models with a voltage output, replace 20 mA accordingly with 10 V.

Product Information

Sensors and Instrumentation

Edit, using position 2

If the currently visible parameter is to be modified:

- Turn the annular gap to position 2, so that a flashing cursor appears which displays the position which can be modified.
- By repeatedly turning to position 2, values are increased; by turning to position 1, the cursor moves to the next digit.
- Leave the parameter by turning to position 1 (until the cursor leaves the row); this accepts the modification.
- If there is no action within 30 seconds, the device returns to the normal display range without accepting the modification.

The limit switches S1 and S2 can be used to monitor minima or minima or maxima.

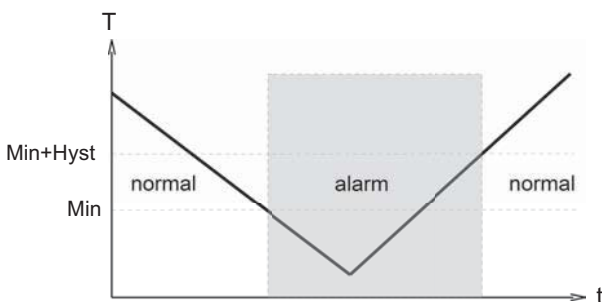

With a minimum-switch, falling below the limit value causes a switchover to the alarm state. Return to the normal state occurs when the limit value plus the set hysteresis is once more exceeded. With a maximum-switch, exceeding the limit value causes a switchover to the alarm state. Return to the normal state occurs when the measured value once more falls below the limit value minus the set hysteresis.

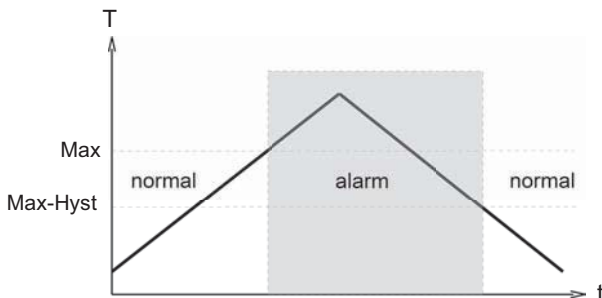

The change to the alarm state is indicated by the integrated red LED and a cleartext in the display. While in the normal state the switching outputs are at the level of the supply voltage; in the alarm state they are at 0 V, so that a wire break would also display as an alarm state at the signal receiver.

Overload display

Overload of a switching output is detected and indicated on the display ("Check S 1 / S 2"), and the switching output is switched off.

Simulation mode

To simplify commissioning, the sensor provides a simulation mode for the analog output. It is possible to create a programmable value in the range 0..26.0 mA at the output (without modifying the process variable). This allows the wiring run between the sensor and the downstream electronics to be tested during commissioning. This mode is accessed by means of **Code 311**.

Factory settings

After modifying the configuration parameters, it is possible to reset them to the factory settings at any time using **Code 989**.

Ordering code

The basic device is ordered e.g. MID1-xxx with electronics e.g. OMNI-MID1-xxx

MID1- 1. 2. 3. 4. 5.
 MID1- A P E

OMNI-MID1- 6. 7. 8.
 OMNI-MID1- S

○=Option

1. Nominal width				
008	DN 8 - R 1/4"			
015	DN 15 - R 1/2"			
025	DN 25 - R 1"			
2. Process connection				
A	male thread			
3. Housing material				
P	PPS			
4. Metering range				
001	0.05.. 1 l/min			•
010	0.50..10 l/min			•
060	3.00..60 l/min			•
5. Connection for				
E	electronics			
6. For nominal width				
008	DN 8 - R 1/4"			•
015	DN 15 - R 1/2"			•
025	DN 25 - R 1"			•
7. Analog output				
I	current output 0/4..20 mA			
U	○ voltage output 0/2..10 V			
8. Electrical connection				
S	for round plug connector M12x1, 5-pole			

Options

- Housing material PEEK

Accessories

- Cable/round plug connector (KB...) see additional information "Accessories"
- Device configurator ECI-1