

# Food & Beverage – Flavouring dosing

Application note A030C-FB04D04-0213B



The use of expensive and often volatile additives is critical for many industries, especially food and beverage where the precise dosing of flavourings is key to product quality and the reduction of waste.

Bronkhorst Cori-Tech understands the market needs and can provide customized solutions to control the precise addition of flavours, fragrances or other additives.



Roller showing extrusion of the product into long strips before cutting into bars.

- ◆ Cereal bar
- ◆ Fruit bar
- ◆ Breakfast cereals

## Application requirements

The dosing of additives needs a high accuracy and stability of the flow to prevent product wastage. This can be achieved by the use of a Bronkhorst Coriolis mass flow meter directly linked to a liquid dosing pump to provide closed loop control.

This gives both flow verification and also precise control on pump operation, often much beyond normal pump design limits. Where master - slave operation is desired in conjunction with the main flow line, this can also be incorporated into the system.

### Important topics

- ◆ High accuracy
- ◆ Stable control
- ◆ Direct pump control
- ◆ Complete compact system

## Process solution

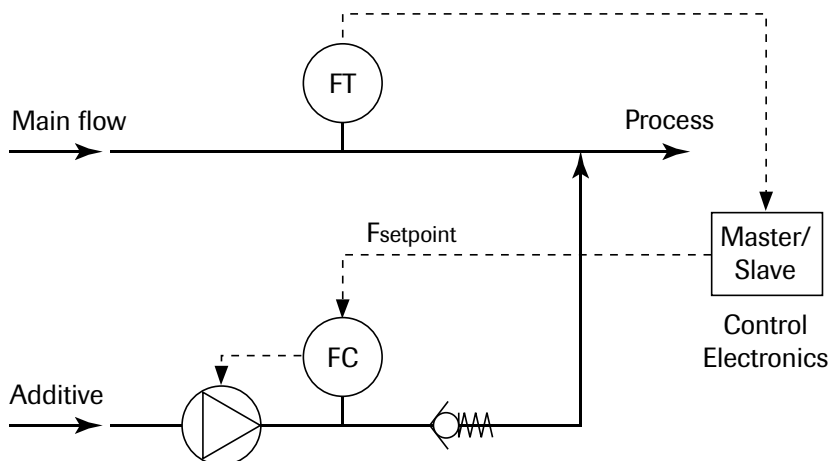

A schematic technical diagram showing our product included in the customer's process

### Dosing of flavourings

The main flow is often much larger than that required for the additive and can be measured by a conventional flow meter i.e. Coriolis or even electromagnetic flow meter. The output from this master flow meter is connected into the Bronkhorst FLOW-BUS via the use of our E-7000 readout and interface module. A user configurable slave factor can be entered into these electronics for each "recipe" that is required for that production run.

The Bronkhorst mini CORI-FLOW™ acts as the slave instrument and receives its setpoint from the E-7000 electronics. When the master flow rate varies, the setpoint to the slave instrument is automatically adjusted by a customer configurable slave factor. The integrated PID-controller within the CORI-FLOW™ recalculates the control signal to the pump via an inverter which converts the drive voltage into pump rotation, to swiftly reach the desired flow rate. ▶

Additional functionality is also possible as standard including pump protection via the programmable response alarm or density measurement to monitor entrained gas. Bronkhorst can also supply an optional pressure sensor as part of the system to prevent an overpressure situation. This provides a compact and precise system for the repeatable, accurate measurement and control of additives and is especially suitable for multi-product applications, due to the use of Coriolis mass flow technology. ■



## Recommended Products



**mini CORI-FLOW™ M12 / M13 / M14**  
compact Coriolis Mass Flow Controller for liquids and gases. Both analog and digital output. Housing according to IP65 classification. **World's smallest Coriolis Mass Flow Controller!**

- ◆ Direct mass flow measurement, for liquids and gases
- ◆ High accuracy, excellent repeatability
- ◆ Cost-effective design
- ◆ Compact design, with integrated PID controller for fast and stable control
- ◆ Now suitable for (very) low flow ranges



### Panel Mount Readout / Interface

Advanced micro-processor based power supply / readout systems with easy push-button and many functions, such as alarms, totalisation, reading of actual flow and indication of fluid names.

- ◆ User-friendly, menu driven with 5 push buttons
- ◆ Suitable for digital or analog instruments
- ◆ Indication of measured value on a 2-line
- ◆ 16-figure display in percent or direct indication
- ◆ Internal/external command
- ◆ Master/Slave control
- ◆ Totalization or batchcounter functions
- ◆ Programming of 8 polynomial functions per module

## Contact information



T +31(0)573 45 88 90 F +31(0)842 29 23 75  
I [www.bronkhorst-cori-tech.com](http://www.bronkhorst-cori-tech.com)  
E [info@bronkhorst-cori-tech.com](mailto:info@bronkhorst-cori-tech.com)

**Flavouring dosing**  
A030C-FB04D04-0213B

FB: Food & Beverage  
04: Food processing  
D04: Dosage, additives

